

# 2024



WE TURN HEADS



**Adzone Global for Advertising is a Kuwaiti based Advertising and Media Company established by a group of experts in 2019.**

It is by far the fastest growing digital out – of – home advertising company in Kuwait and the region.

We are a part of a clear channel of Kuwait's digital out -of home advertising companies with a circuit consisting of **45** screens in prime locations covering Kuwait's six governorates.



# WHO ARE WE

Adzone Global for Advertising serves a variety of vertical markets including large formats such as digital billboards and street level strategically placed including malls, office buildings, gas stations, and point of purchase found in convenience stores, office buildings and commercial buildings .

Ad Zone connects people with real-time visual information where and when they need it.

AD Zone helps you achieve real business goals - increase and accelerate revenues, reduce impressions costs, improve customer loyalty, and build brand equity,

W E T U R N H E A D S

# ADZONE GLOBAL



**Adzone** Global for Advertising built a reputation for +200 result-oriented campaigns, and are innovative in developing unbeatable DOOH media expertise.

With our signature large format **DOOH** screens like the **Monster** and the **Giant** characterized by their high resolutions and cinema quality video you can maximize your brand reach and connect engage and create an impact on your audiences everywhere .



Quividi is the pioneer and world`s #1 in AI & Computer based platforms providing real- time audience measurement for Digital out Out-of\_home (Dooh)

Quividi Audience Measurement Platform (AMP )is composed of a core solution marrying VidiReports DOOH, a software that runs locally on the player attached to the screen, with VidiCenter a rich online back-office solution for analysis and management.



# The Monster Experience

One of our largest formats which is the Monster screen is a monstrous sized screen.

Our Monster screens have the power to create a long-lasting impression . Engage audiences, create impact, and get your message out there in a huge Monstrous way Take your brand or services on the best localities of Capital city and reach places other media tools can't. This is your chance to connect with audiences where you can shout the loudest. Think main traffic routes, festivals, or right on the doorstep of your competitors.

W E T U R N H E A D S

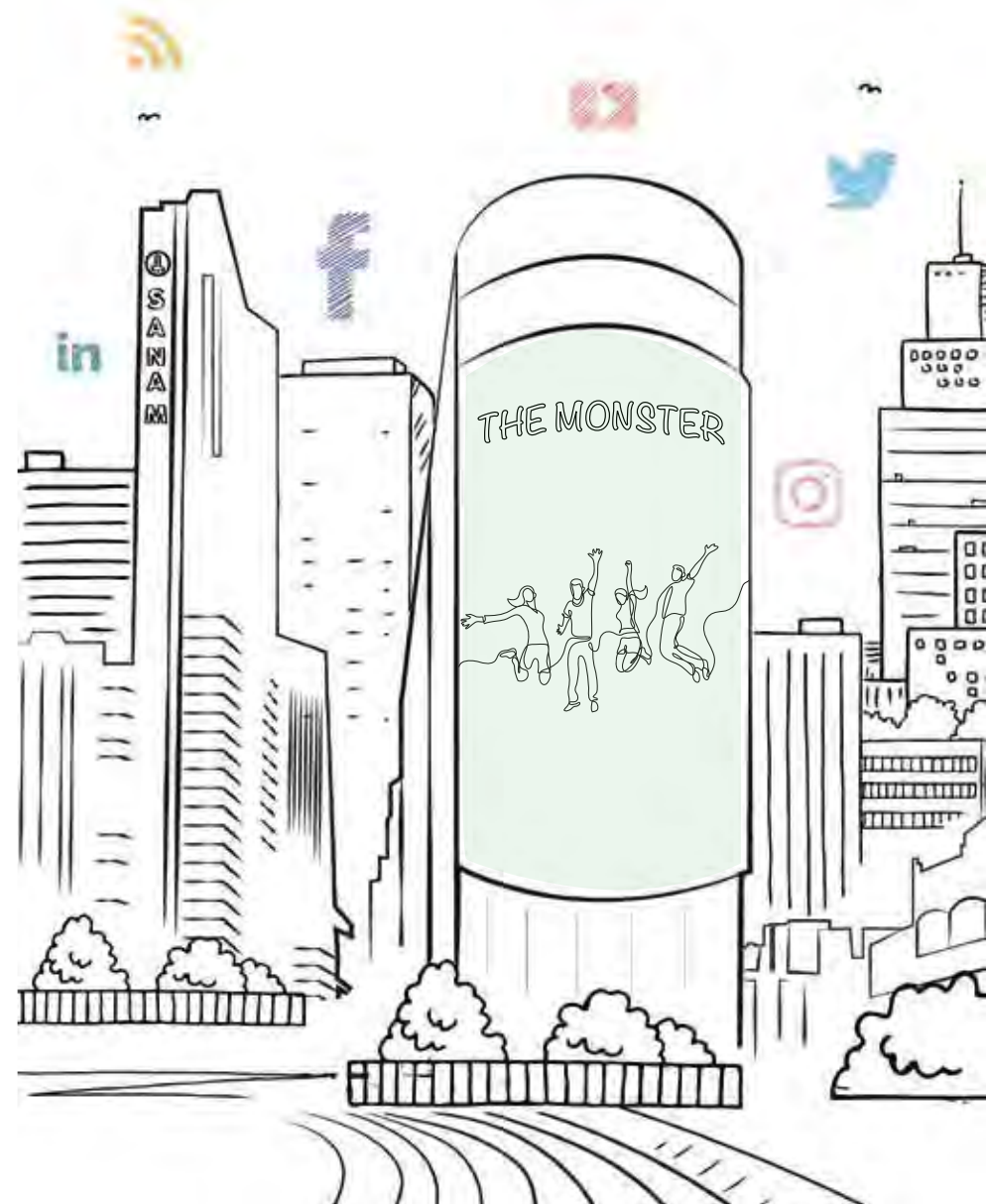



# SCREEN LOCATIONS

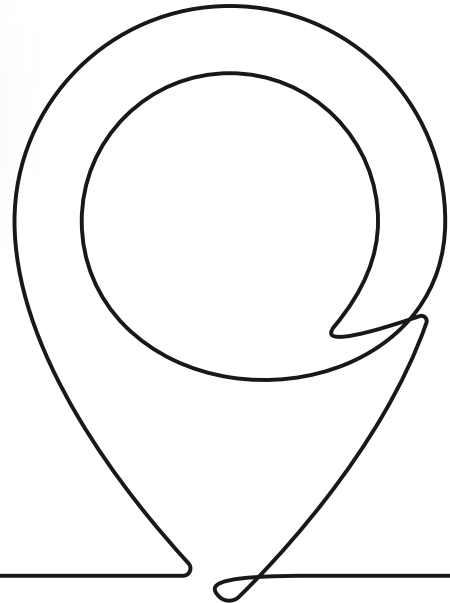

WE TURN HEADS

ADZON

# THE MONSTER

WE TURN HEADS



# The Monster

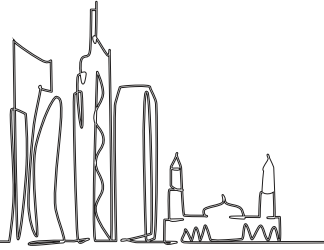

The Monster Screen is located at the Capital City at the crossroads of Fahad Al Salem St. & Ali Al Salem St. dominating the main entrance of Al Mubarkia Souq Kuwait City

## Specs.

Resolution : 2400 x 2976 p

96p as bleed

Size : 28x36

Track the views per week

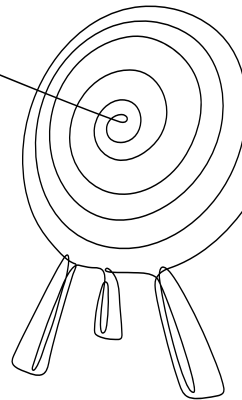
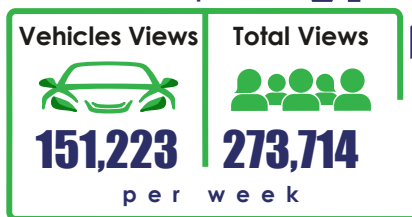

# Ratecard

Annual subscription

10 seconds 145,000 K.D

Monthly subscription

10 seconds 15,000 K.D

Two Weeks subscription

10 seconds 9,000 K.D

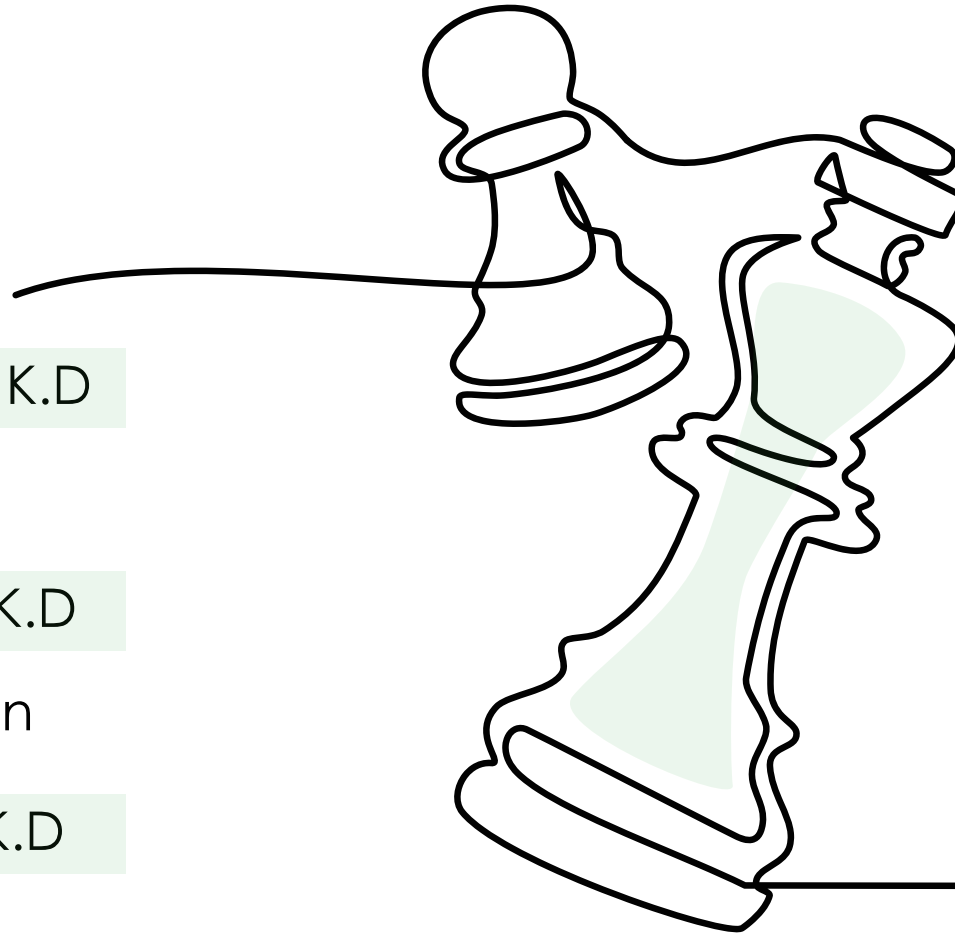

# The Giant

Following our next large format is The Giant screen which extends beyond your field of vision.

The Giant screen extends beyond your field of vision, for a completely lifelike experience. With its perfect visual effect and experience, high precision curve towards the edges, it uses the unique context to add perceived brand value.

It also provides a welcome unavoidable distraction to a captive audience and engages different types of buyer categories. It is proven like FMCG & FMB to drive sales in key accounts, in sectors cars, teleco,.. retailers. It connects with alert consumers in a unique environment and receptive mindset.



**Shaha Commercial Complex  
Salem Al Mubarak St  
Salmiya**



## Specs

Resolution: 8440x840p

200p as a bleed on the sides

Dimension: 77.5x6m

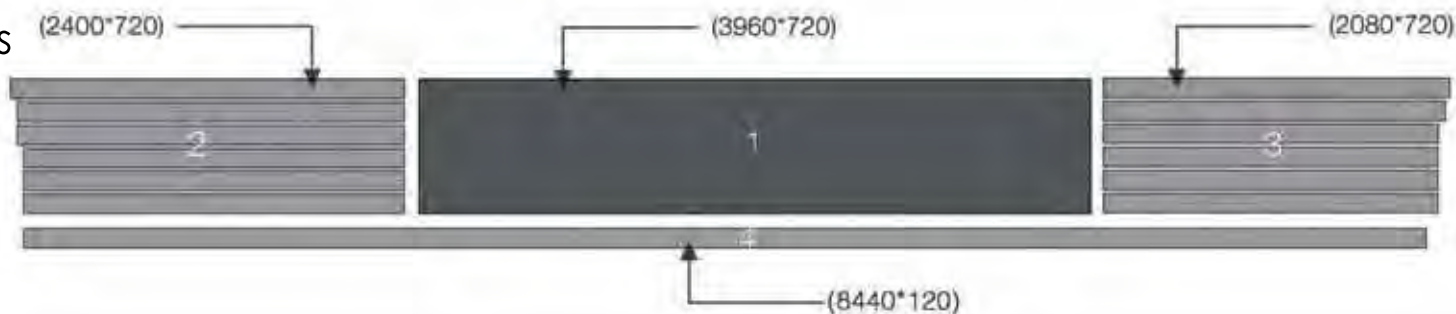

Track the views per week

Vehicles Views

Total Views



**178,646**

**323,349**

per week

The Giant Screen is located at Shaha Commercial Complex at Salem Al Mubarak St, Salmiya Covering Gulf Road, Qatar St, Salem Al-Mubarak St.

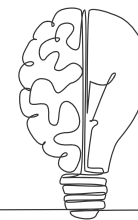

# Ratecard



Annual subscription

10 seconds 145,000 K.D

Monthly subscription

10 seconds 15,000 K.D

2 Weeks subscription

10 seconds 9,000 K.D





# The New 3D Screen





The first

# 3D

## Anamorphic Screen

in Kuwait is located in one of Kuwait's six governorates, 4th Ring Road (Mohamed Abdullah Al Bahar Complex) in a 24hrs busy area where contents are shown at eye level for maximum awareness to mass audiences

Track the views per week

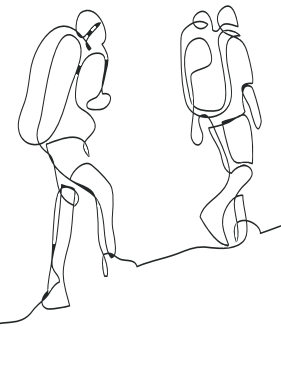
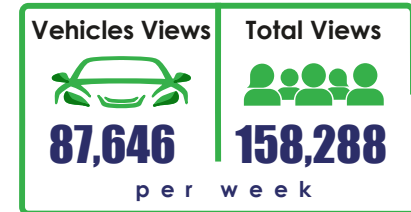

# Located in 4th Ring Road

(Mohamed Abdullah Al Bahar Complex)

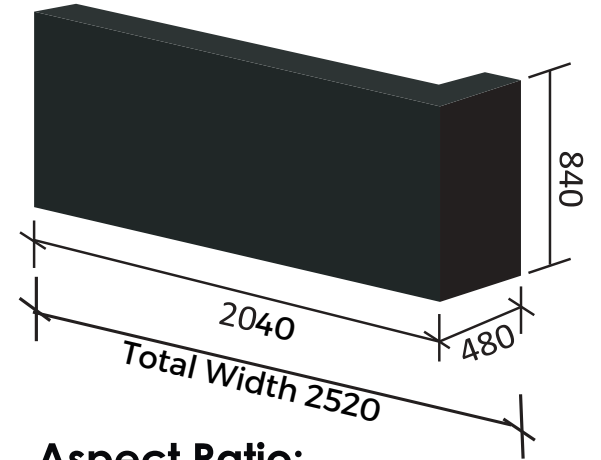

**Aspect Ratio:**  
**3 : 1**  
**Total Width:**  
**2520**  
**Dimension:**  
**21 x 7**

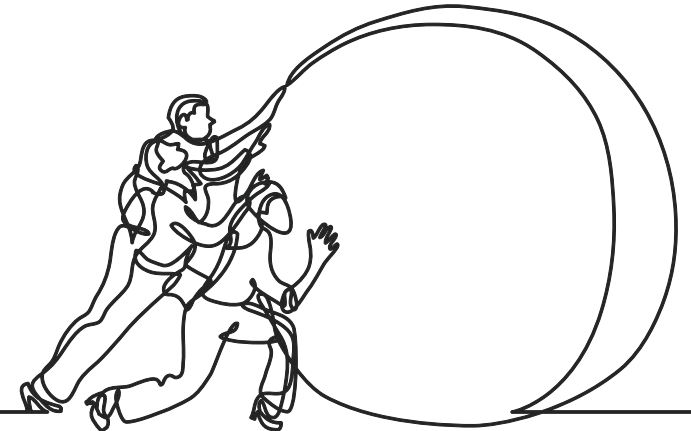



# Ratecard

Annual subscription

10 seconds - 72,500 KD

Monthly subscription

10 seconds - 7,500 KD

Two Weeks subscription

10 seconds - 4,000 KD

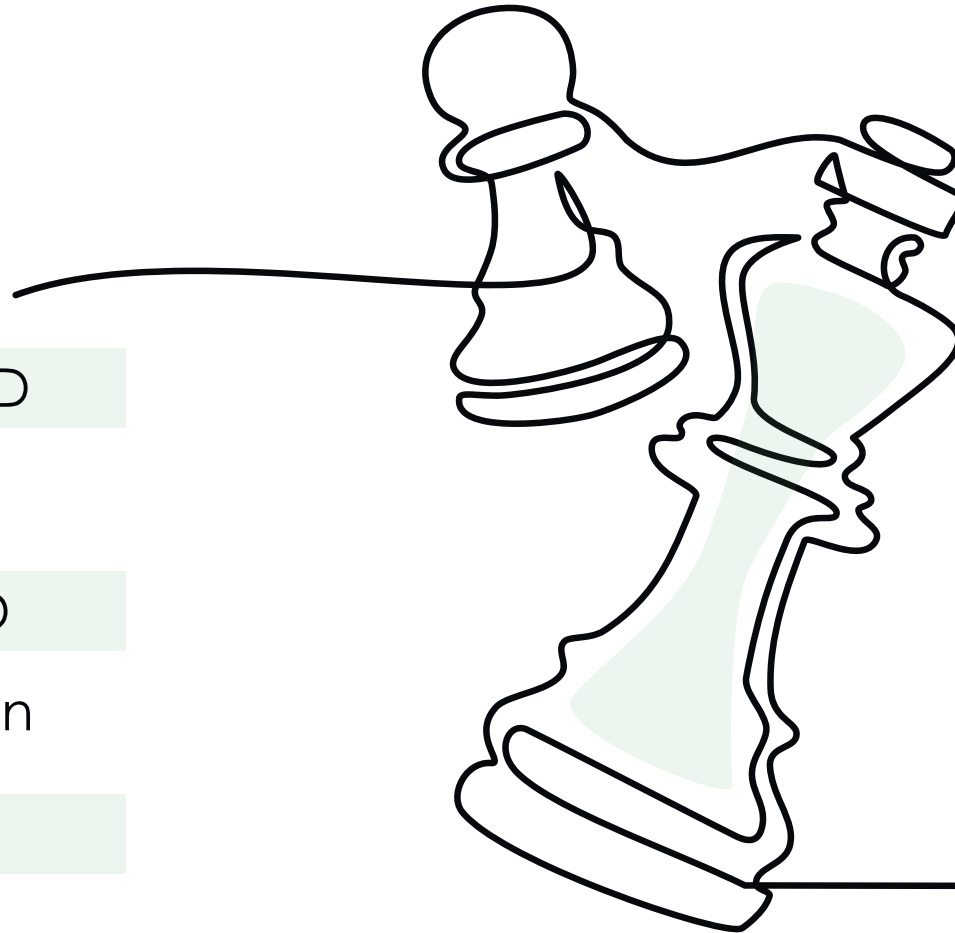

# 11

## OUTDOORS

Our digital out-of-home screens strategically positioned in the high traffic areas in the six governorates of Kuwait ensure that your products or services are reaching all their potential customers. Our Outdoor digital screens will increase your brand awareness by being fully customizable to your particular brand, target audience, and marketing goal and help boost your Sales by providing maximum exposure and showing the world what your brands and services can do. We also enable the maximum audience awareness of your brand or services while experiencing it seamlessly through integrated marketing campaigns through our outdoor media having massive 4,184 sqm screens having the highest repeat orders in the **DOOH** Market .

With our outdoor screens which are characterized by high resolution and cinema quality video you can maximize your brand reach.

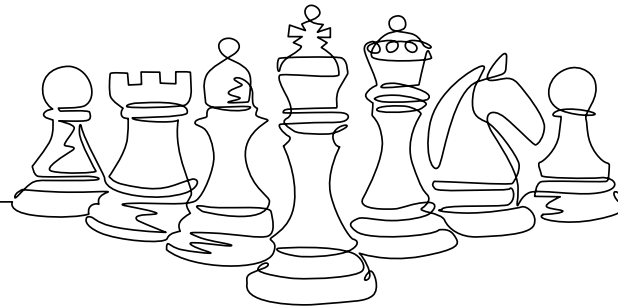

WE TURN HEADS

# Outdoors

Salwa	18x6 m
Al Farwaniya	13x15 m
Jabriya	18x6 m
Kuwait City	15x5 m
Jahra	15x5 m
Khiran Square	17x5 m
Fahaheel	18x6 m
Eqaila	18x6 m
Salam Mall	22x4m
The Lake Mall	20x7 m
Ministry Complex	6x10 m

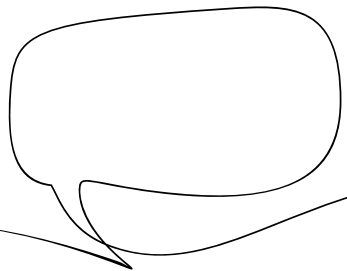



# FARWANIYA

Ali Fahad Al Dewailah St - Radi  
Al Owayid Complex  
Dimension: 15x13m  
Resolution: 1300x1500p

Track the views per week

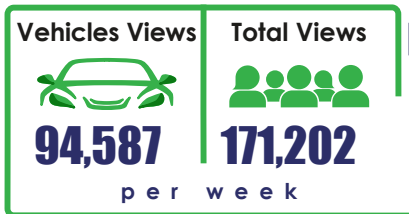

WE TURN HEADS

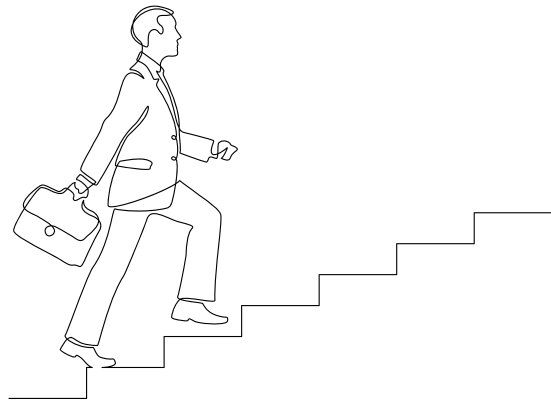

# Salwa

Block 5, Salem Ganim Al Herayis Street,  
above Salwa Main Co-op  
Dimension: 18x6m Resolution: 1200x400p

Track the views per week

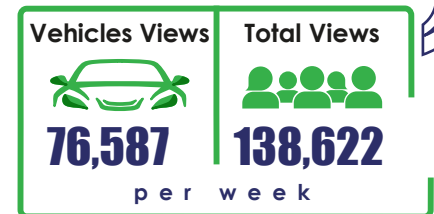

all copyrights reserved to AD ZONE Global 2024

# JABRIYA

Dimensions: 18x6m  
 Resolution: 1200x400p  
 Traffic (per 2 weeks): 157,000  
 Kuwaitis: 92%  
 Visits (per 1 week): 2.4  
 Census: 116941

Track the views per week

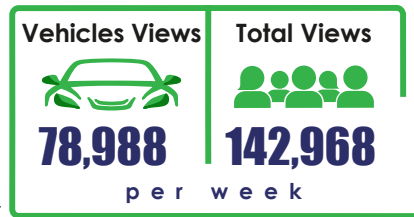

# KUWAIT CITY

Facing Stock Exchange  
 Dimension: 13x5m  
 Resolution: 1200x400p

Track the views per week

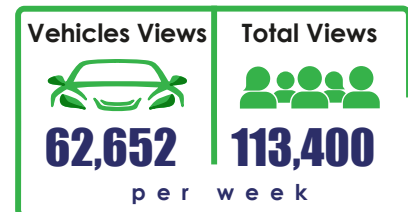

WE TURN HEADS



# KHIRAN SQUARE

Dimensions: 17x5m  
 Resolution: 720x600p  
 Traffic (per 2 weeks): 127,000  
 Kuwaitis: 91%  
 Visits (per 1 week): 2.3  
 Census: 29140

Track the views per week

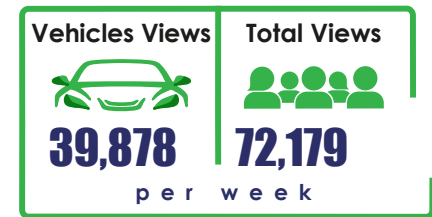

# JAHRA Jawhara Complex

Resolution: 1200x400p  
 Dimension: 13x5 Meter

Track the views per week

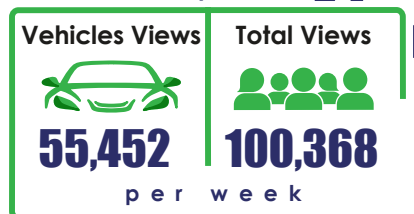

WE TURN HEADS

# FAHAHEEL

Al Dabbous Round About  
Opposite Rotana Hotel  
Dimension: 18x6m  
Resolution: 1200x400p

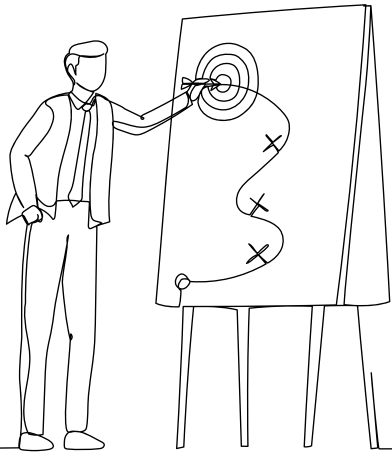

Track the views per week

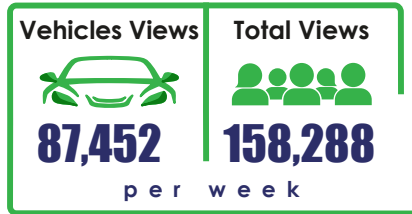

# Egaila

Opposite TSC  
Dimension: 15x6m  
Resolution: 1200x400p

Track the views per week

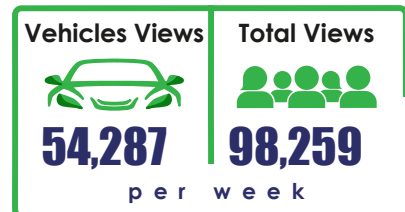

# SALAM MALL

Salmiya

Dimension: 22x4m

Resolution: 1200x400 Pixels

Track the views per week

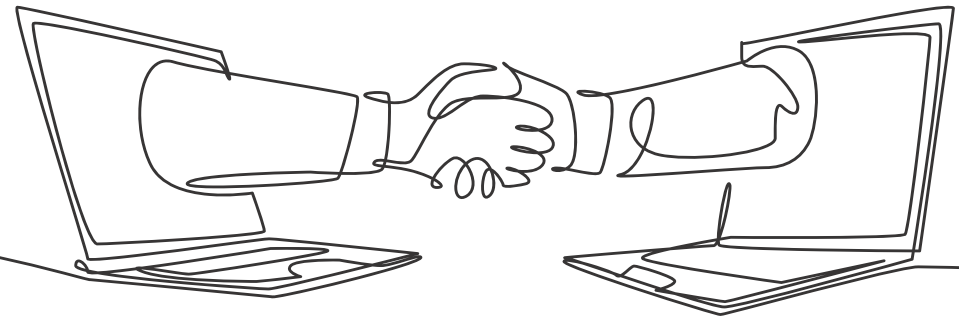
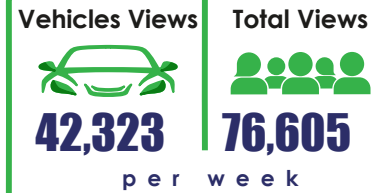

WE TURN HEADS



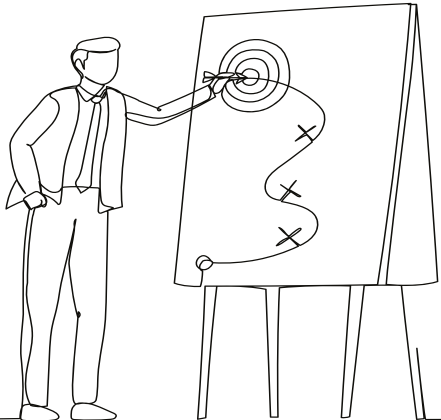

## The Lake Mall

Dimensions: 20x7m  
Resolution: 1200x400p  
Traffic (per 2 weeks): 127,000  
Kuwaitis: 91%  
Visits (per 1 week): 2.3  
Census: 29140

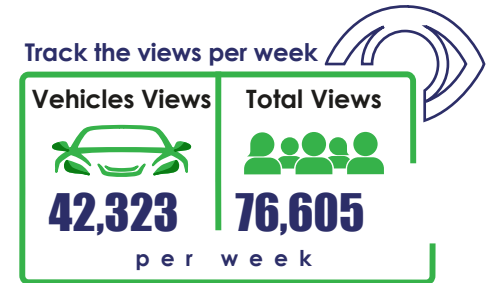



## Ministry Complex

Dimensions : 6 x 10 m

Resolution : 720 x 1200p

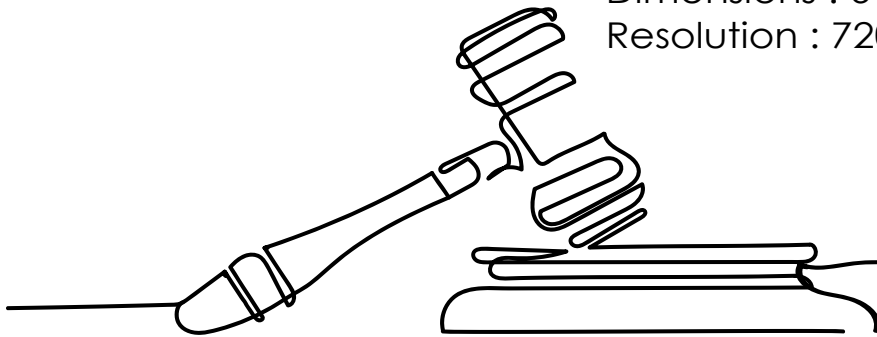

Track the views per week

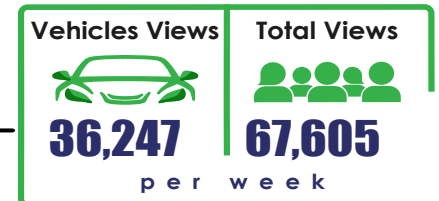

WE TURN HEADS

# Outdoors

2 Weeks

subscription

10 seconds 1,500 K.D

Circuit subscription

10 seconds 12,500 K.D

4 Weeks

subscription

10 seconds 2,500 K.D

Circuit subscription

10 seconds 22,500 K.D

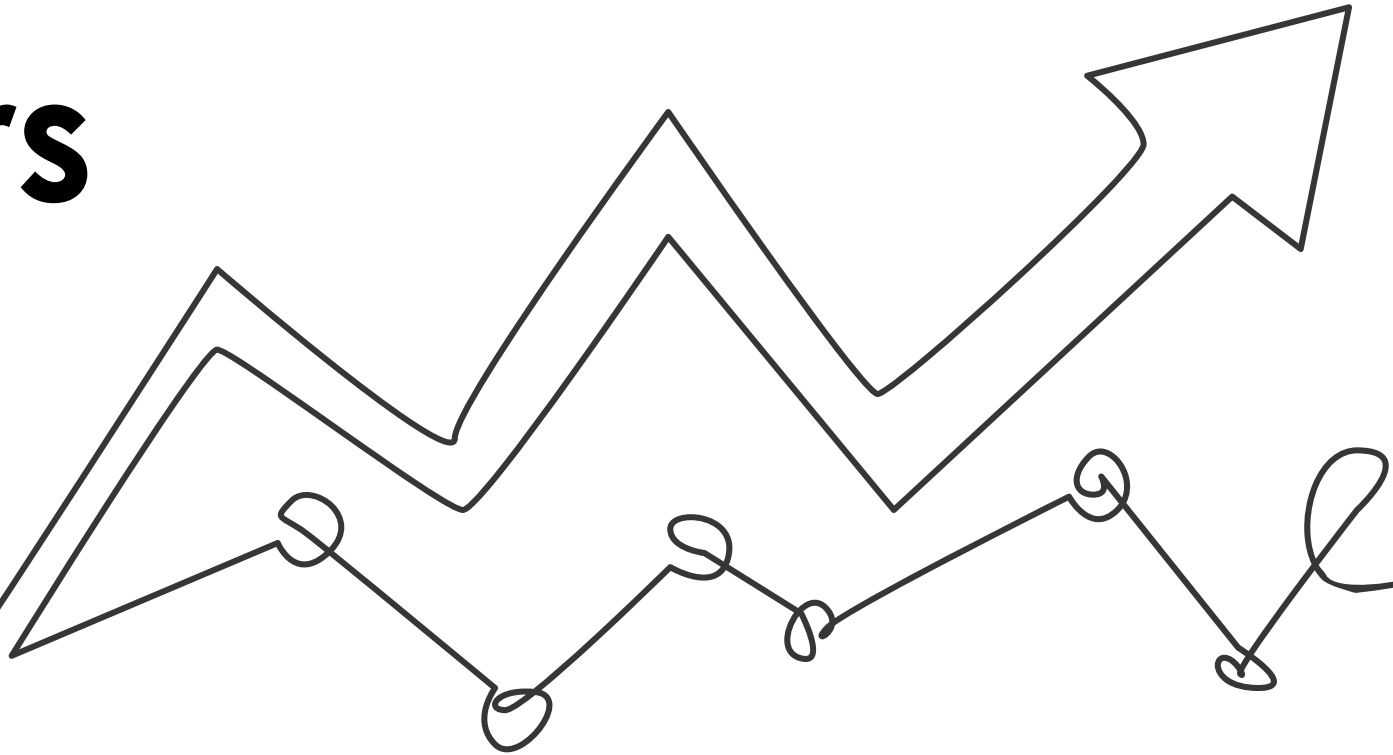

# BEST LOCAL COMMUNITY

4,779,000



TOTAL FOOTFALL  
PER 2 WEEKS



Location

%92.72



KUWAITIS

Kuwait has about **50 co-ops**, affiliated to which are **70 central markets** and about **3,000 sub-markets** offering their services to more than **2.5 million Kuwaitis** and residents. we plan on more all over Kuwait to help you introduce your product or service to a large and diverse market and achieve faster and higher brand recognition. This is your chance to connect with audiences where you can shout the loudest. Think main traffic routes, festivals, or right on the doorstep of your competitors.

# Community Screens Network

Abu Halifa	13x5 m
Mubarak Al Kaber	10x5 m
Abu Fatira	10x5 m
Abdullah Al-Salem	15x5 m
Al Daiya	6x7 m
Shaab	10x5 m
Al Fintas	18x6 m
Salwa	6x7 m
Al Qarin	10x5 m
Eshbiliya	5x2 m
Al Adiliya	9x3.5 m
Al Rihab	10x5 m
Al Sulaybikhat	12x5 m
Mansouriya	15x5 m
West Mishref	6x5 m
Doha	8x4 m

Al Nuzha	15x5 m
Al Jahra	4.5x1.8 m
Al Ardiya	10x4 m
Fahahel	4.5x1.8 m
Al Shamiya	18x6 m
Sabah Al Salem	15x5 m
Qortuba 2	4.5x1.8 m
Al Yarmouk	5x4 m
Al Surra	4.5x1.8 m
Bayan	3.5x4.5 m
Meshref 1	5x5 m
Meshref 2	5x5 m
Qortuba 1	4x3 m
Qadsiya	15x5 m
Al Khaldiya	4.5x1.8 m
Kaifan	8x6m

3.5x4.5 m

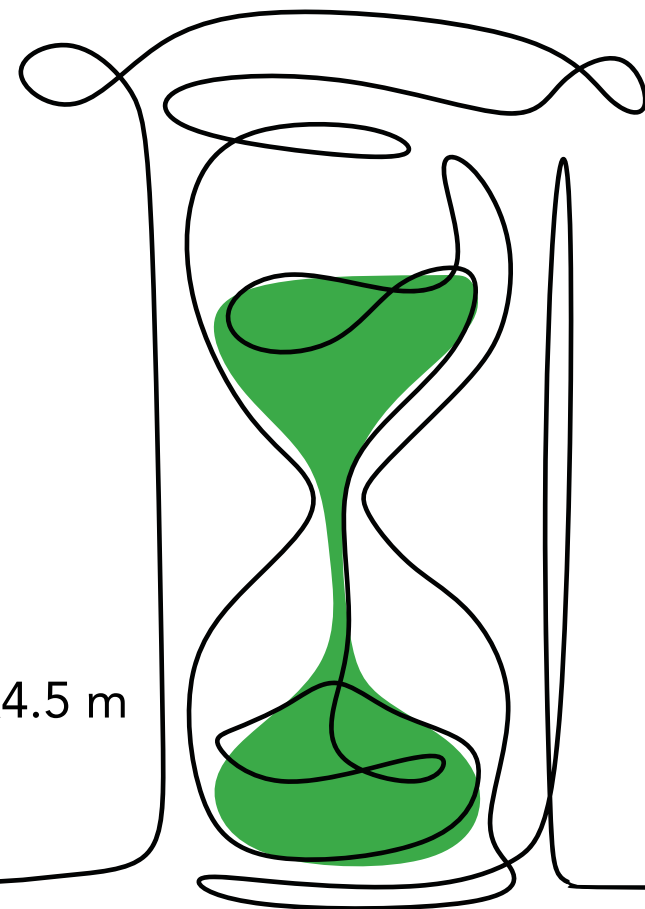



## MUBARAK AL-KABER

Dimensions: 10x5m  
 Resolution: 1200X400p  
 Traffic (per 2 weeks): 133,000  
 Kuwaitis: 91%  
 Visits (per 1 week): 2.1  
 Census: 50351

Track the views per week

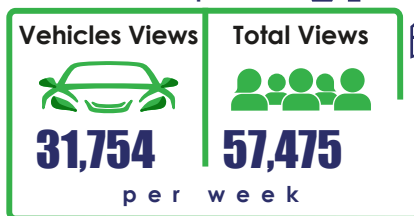

## ABDULLAH AL-SALEM

DIMENSION:15X5  
 RESOLUTION :1200X400  
 Traffic (per 2 weeks): 97,000  
 Kuwaitis: 94%  
 Visits (per 1 week): 2.1  
 Census: 22143

Track the views per week

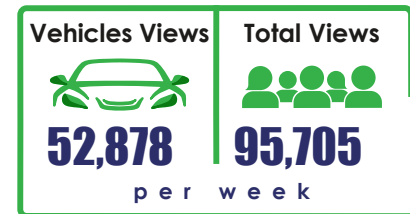

# ABU FATIRA

Dimensions: 10x5m  
 Resolution: 720x600p  
 Traffic (per 2 weeks): 93,000  
 Kuwaitis: 84%  
 Visits (per 1 week): 2.1  
 Census: 8553

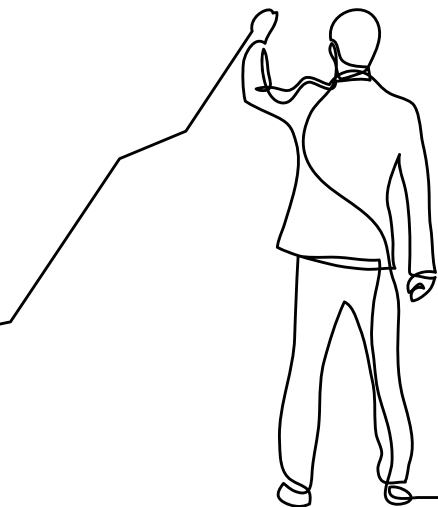

Track the views per week

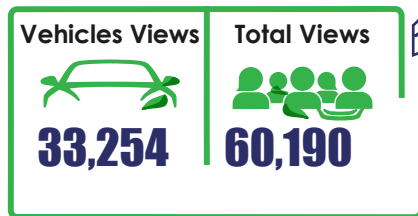

# AL DAIYA

Dimensions: 6x7m  
 Resolution: 500x600p  
 Traffic (per 2 weeks): 157,000  
 Kuwaitis: 92%  
 Visits (per 1 week): 2.4  
 Census: 20147

Track the views per week

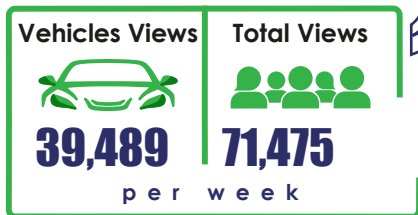

# SHAAB

Dimensions: 10x5m  
 Resolution: 1200x400p  
 Traffic (per 2 weeks): 132,000  
 Kuwaitis: %88  
 Visits (per 1 week): 2.3  
 Census: 47734

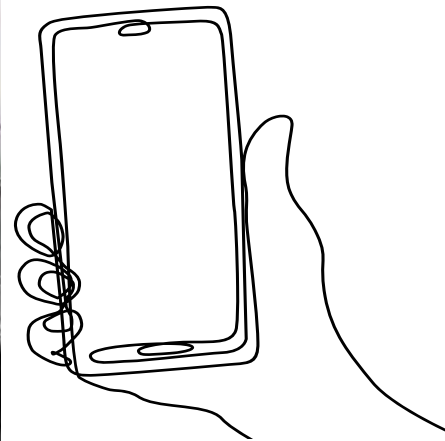
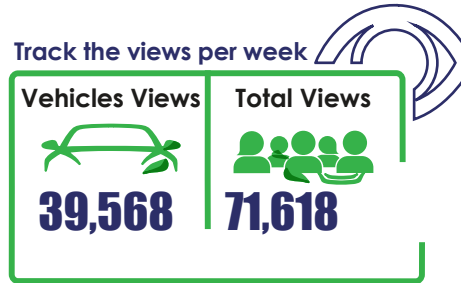

# AL FINTAS

Dimensions: 15x5m  
 Resolution: 1200X400p  
 Traffic (per 2 weeks): 161,000  
 Kuwaitis: 97%  
 Visits (per 1 week) : 2.4  
 Census: 44327

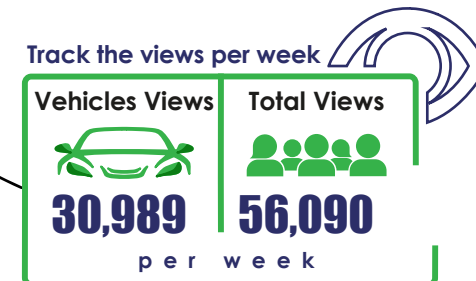



# SALWA

Dimensions: 6x7m  
 Resolution: 500x600p  
 Traffic (per 2 weeks): 112,000  
 Kuwaitis: %87  
 Visits (per 1 week): 2.4  
 Census: 81620

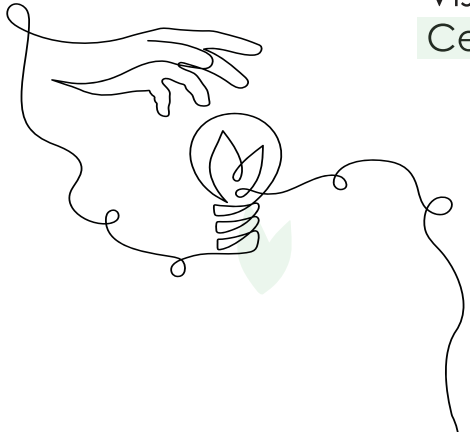

Track the views per week

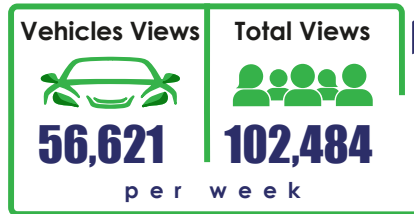

# ESHBILIYA

Dimensions: 5x2m  
 Resolution: 1200x400p  
 Traffic (per 2 weeks): 125,000  
 Kuwaitis: %89  
 Visits (per 1 week): 2.2  
 Census: 34694

Track the views per week

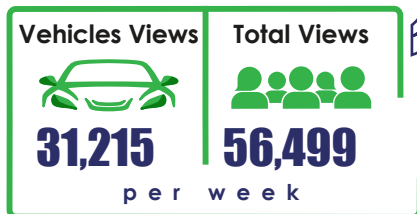

# AL QURAIN

Dimensions: 10x5m  
 Resolution: 1200x400p  
 Traffic (per 2 weeks): 194,000  
 Kuwaitis: 89%  
 Visits (per 1 week) : 2.3  
 Census : 36112

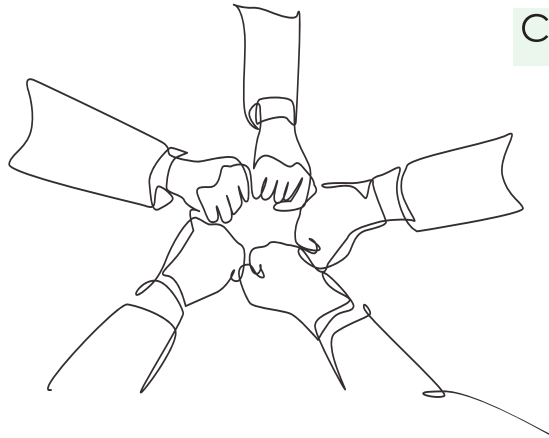

Track the views per week

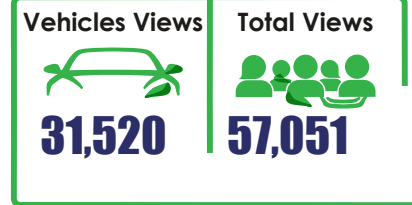

# FAHAHEL

Dimensions: 4.5x1.8m  
 Resolution: 1200x400p  
 Traffic (per 2 weeks): 121,000  
 Kuwaitis: %87  
 Visits ( per 1 week): 2.2  
 Census: 108010

Track the views per week

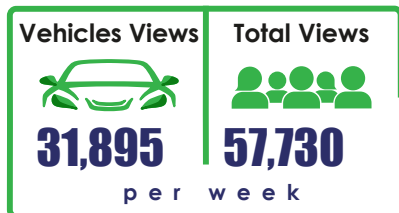

# AL SULAYBIKHAT

Dimensions: 10x5m

Resolution: 1200X400p

Traffic (per 2 weeks): 201,000

Kuwaitis: 88%

Visits (per 1 week): 2.3

Census: 34794



Track the views per week

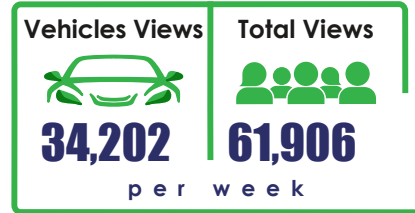

# MANSOURIYA

Dimensions: 10x5m

Resolution: 1200x400p

Traffic (per 2 weeks): 161,000

Kuwaitis: 97%

Visits (per 1 week): 2.4

Census: 18328

Track the views per week

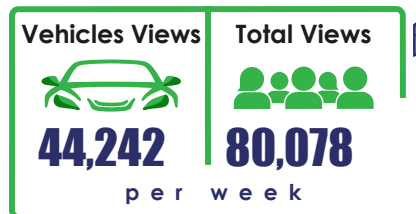

# WEST MESHRIF

Dimensions: 6x5m

Resolution: 720 x 600p

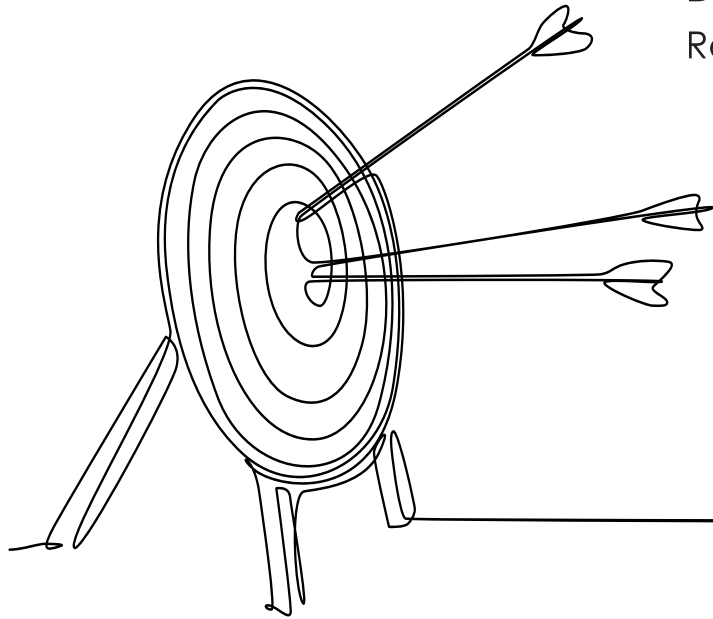

Track the views per week

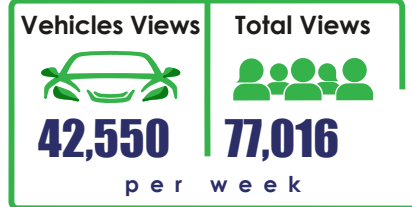

# ABU HALIFA

Dimensions: 13x5m Resolution: 1200X400p

Traffic (per 2 weeks): 78,000 Kuwaitis: 82%

Visits (per 1 week) : 2.2 Census: 56906

Track the views per week

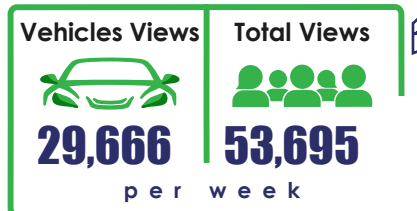

# DOHA

DIMENSION: 8X4  
Resolution: 1200x400p

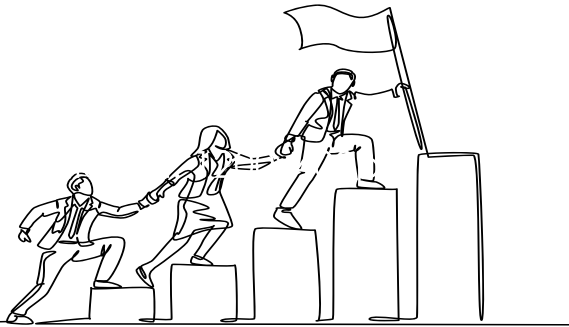

Track the views per week

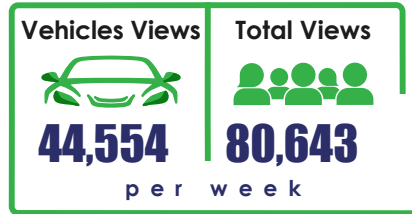

# AL SURRA

Dimensions: 4.5 x 1.8m  
Resolution: 1200x400p  
Traffic (per 2 weeks): 176,000  
Kuwaitis: %89  
Visits ( per 1 week): 2.2  
Census: 37508

Track the views per week

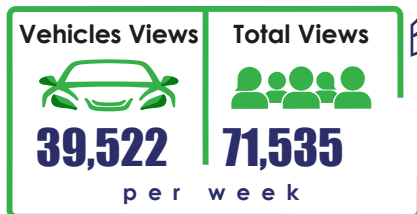

# BAYAN

Dimensions: 4mx6m

Resolution: 470x1250p

Traffic (per 2 weeks): 132,000

Kuwaitis: %88

Visits (per 1 week): 2.3

Census: 47734

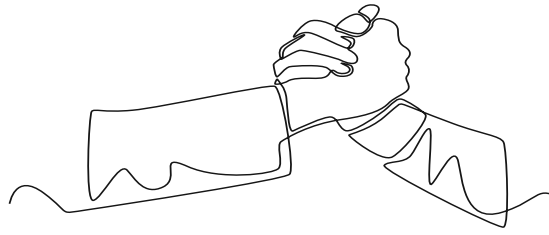

Track the views per week

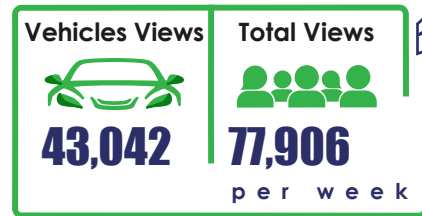

# ALRIHAB

Dimensions: 10x5m

Resolution: 1200x400p

Traffic (per 2 weeks): 133,000

Kuwaitis: 91%

Visits (per 1 week): 2.1

Census: 14946

Track the views per week

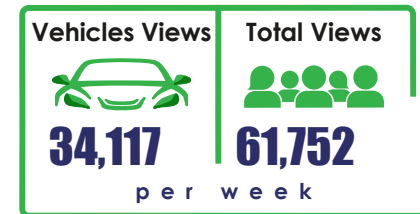

# AL-SHAMIYA

Dimensions: 15x6m  
 Resolution: 1200x400p  
 Traffic (per 2 weeks): 161,00  
 Kuwaiti: 97%  
 Visits (per 1 week): 2.4  
 Census: 18328

Track the views per week

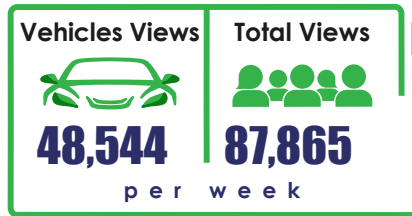

# SABAH AL-SALEM

Dimensions: 15x5m  
 Resolution: 1200x400p  
 Traffic (per 2 weeks): 135,000  
 Kuwaitis: 89%  
 Visits (per 1 week): 2.2  
 Census: 92818

Track the views per week

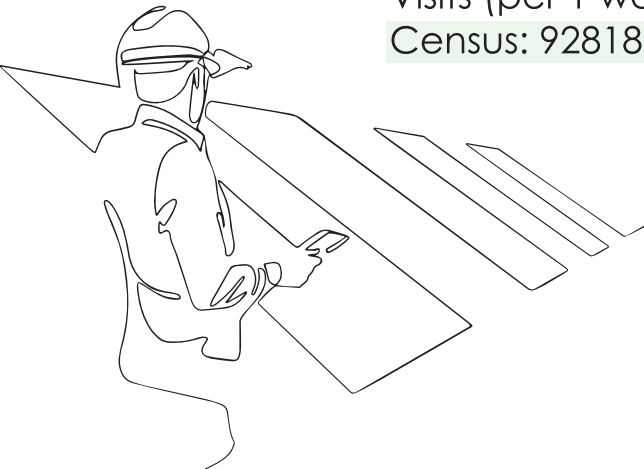
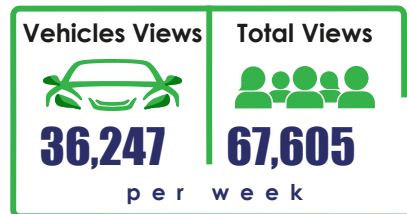



# JAHRA

Dimensions: 4.5x1.8m  
 Resolution: 1200x400p  
 Traffic (per 2 weeks): 133,000  
 Kuwaitis: 84%  
 Visits (per 1 week): 1.9  
 Census: 73948

Track the views per week

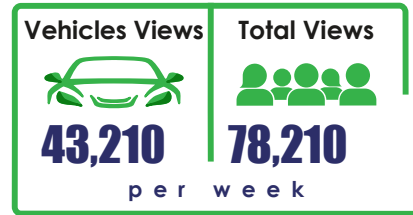

# AL KHALDIYA

Dimensions: 4.5x1.8m  
 Resolution: 1200x400p  
 Traffic (per 2 weeks): 92,000  
 Kuwaitis: %92  
 Visits (per 1 week): 2.2  
 Census: 19615

Vehicles per week :32,111

Total views per week: 58,121

Track the views per week

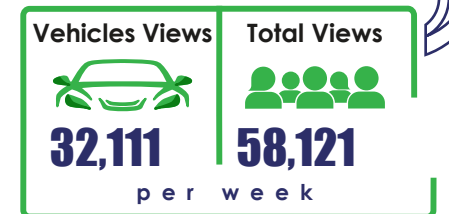



# AL YARMOUK

Dimensions: 3.5x4.5m  
 Resolution: 720x600p  
 Traffic (per 2 weeks): 132,000  
 Kuwaitis: %88  
 Visits (per 1 week): 2.3  
 Census: 25428



Track the views per week

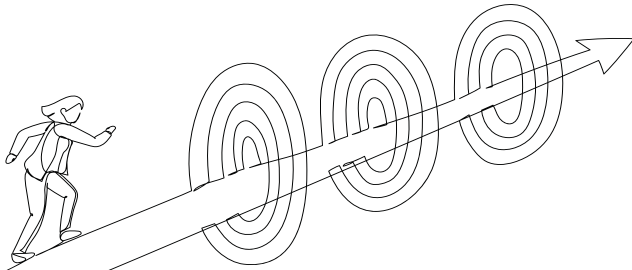
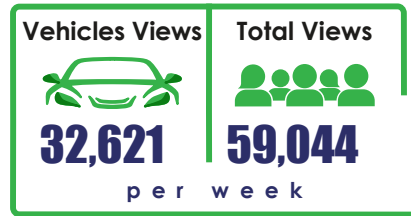

# AL-NUZHA

Dimensions: 10x5m  
 Resolution: 720X600p  
 Traffic ( per 2 weeks ): 81,000  
 Kuwaitis: 93%  
 Visits ( per 1 week ): 2.3  
 Census: 14946

Track the views per week

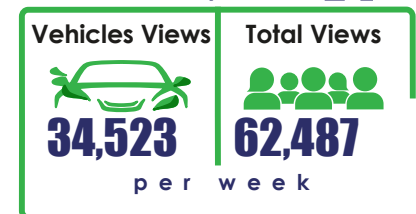

# MESHRIF

Dimensions: 5x5m  
 Resolution: 720x600p  
 Traffic (per 2 weeks): 120,000  
 Kuwaitis: 94%  
 Visits (per 1 week): 2.1  
 Census: 47519



Track the views per week

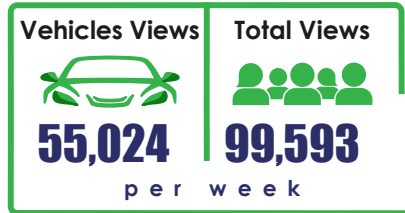

# MESHRIF 2

Dimensions: 5x5m  
 Resolution: 720x600p  
 Traffic (per 2 weeks): 120,000  
 Kuwaitis: 94%  
 Visits (per 1 week): 2.1  
 Census: 47519

Track the views per week

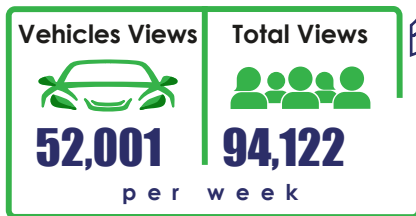



# QORTUBA 2

Dimensions: 3x4m  
Resolution: 720x600p  
Traffic (per 2 weeks): 134,000  
Kuwaitis: %87  
Visits (per 1 week): 2.1  
Census: 34769

Track the views per week

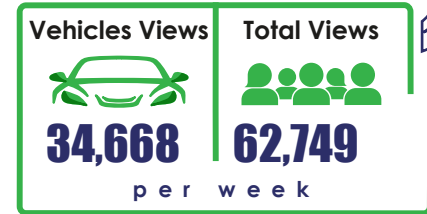

Vehicles per week : 44,554

# Qurtuba

Dimensions: 4.5x1.8m  
Resolution: 1200x400p  
Traffic (per 2 weeks) : 134,000

Kuwaiti : 87%  
Visits (per 1 week) : 2.1  
Census : 34769

Track the views per week

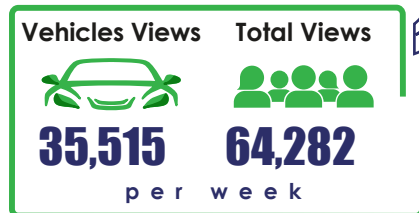

# Qadsiya

Dimensions: 10x5m  
Resolution: 1200x400p

Track the views per week

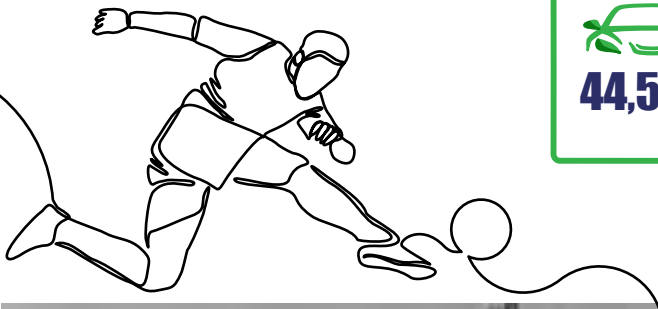
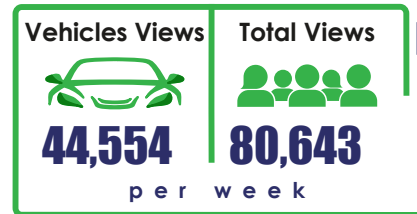

# AL ADILIYA

Dimensions: 4.5x3.5m  
Resolution: 720 x 600p  
Traffic (per 2 weeks): 92,000  
Kuwaitis: %92  
Visits (per 1 week): 2.2  
Census : 19615

Track the views per week

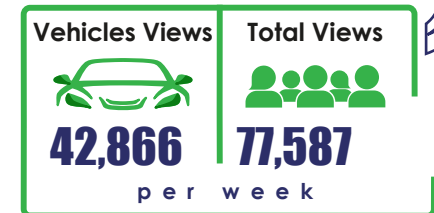



# ALARDIYA

Dimensions: 10x4m  
 Resolution: 1200x400p  
 Traffic (per 2 weeks): 87,000  
 Kuwaitis: 91%  
 Visits per 1 week): 2.2  
 Census: 16071

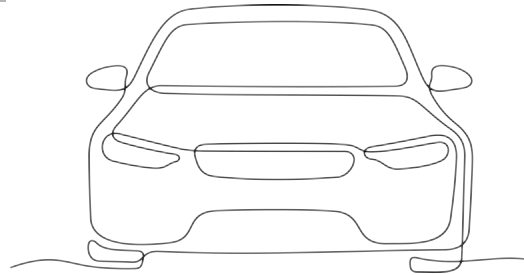
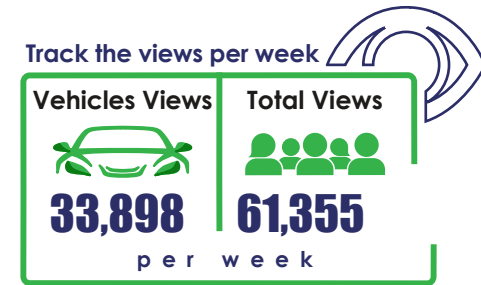

# Kaifan

Dimensions: 8x6m  
 Resolution: 720x600p  
 Traffic (per 2 weeks): 127,000  
 Kuwaitis: 91%  
 Visits (per 1 week): 2.3  
 Census: 29140

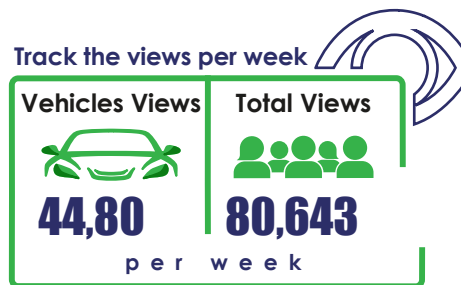

Vehicles per week: 44,554

Total views per week: 80,643

# Ratecard

## subscription

2 Weeks

10 seconds 1,000 K.D

## Circuit subscription

10 seconds 12,500 K.D

4 Weeks

## subscription

10 seconds 1,750 K.D

## Circuit subscription

10 seconds 22,500 K.D

# ASK US ABOUT SERVICES

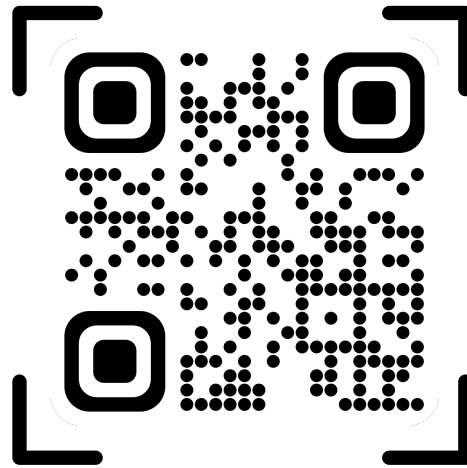

**SCAN ME**

*We Turn Heads*

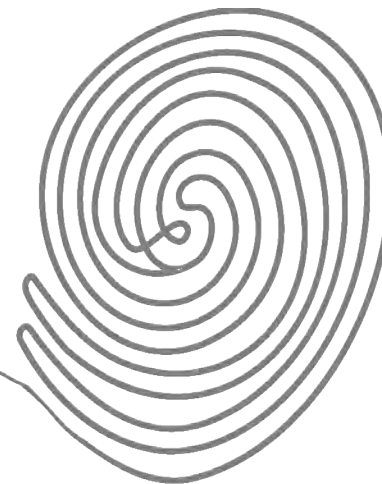

WE TURN HEADS

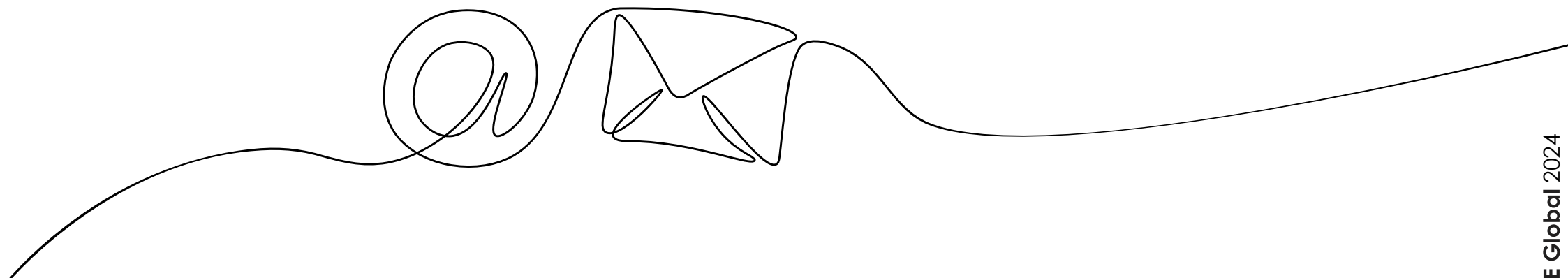

*Thank you*

ad-zonekw



[www.ad-zone.net](http://www.ad-zone.net)



Free Zone, Waves Business Center,  
Block 02 Building 04,G Floor,Office D

W E T U R N H E A D S